

**Single Stage, Belt Drive, Electric Air Compressors**

**D'un seule étape, actionnement pour courroie, compresseur d'air électrique**

**De una sola etapa, accionamiento por correa, compresor de aire eléctrico**

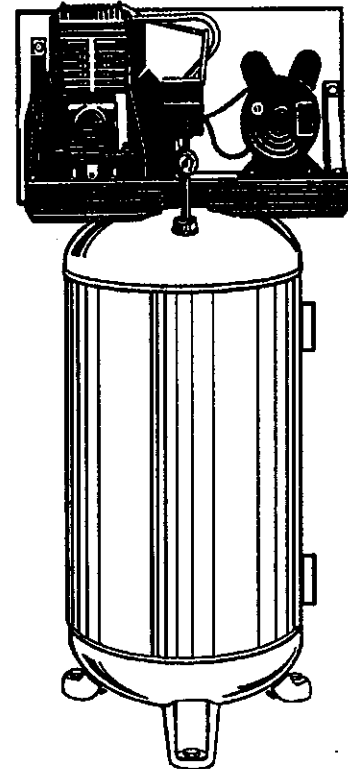

**Specification Chart** \_\_\_\_\_ **Tableau des spécifications** \_\_\_\_\_ **Cuadro de especificaciones**

MODEL NO. (MODÈLE) (MODELO)	H.P. (CV)	TANK CAPACITY GALLONS (CAPACITÉ DU RÉSERVOIR - LITRES) (CAPACIDAD DEL TANQUE - LITROS)	VOLTAGE/ AMPS/PHASE (TENSION/ AMPS/PHASE) (VOLTAJE/ AMP/FASE)	CFM (l/min) @ 40 PSI (2,8 bar)	CFM (l/min) @ 90 PSI (6,3 bar)	KICK-IN PRESSURE (PRESSION D'OUVERTURE) (PRESION DE CONEXION)	KICK-OUT PRESSURE (PRESSION DE FERM.) (PRESION DE DESCONEXION)
L5004416	5	Vert. 44 (166)	230/15/1	12.7 (359)	10.6 (300)	90 (6,3 bar)	120 (8,4 bar)
IL5006016				13.0 (368)	11.1 (314)		
CL5006016		13.4 (380)		11.4 (323)			
L6006016	6	Vert. 60 (228)		13.6 (385)	11.6 (329)		
L6506016	6.5						

\* Prefix Letter – Lettre du préfixe – Letva de prefijo



Questions? See back page. \_\_\_\_\_ Questions ? Consultez la page final. \_\_\_\_\_ ¿Preguntas? Vea la página final.

PN of warning labels (locations C - E)

Nº/ P des étiquettes de avertissement (emplacements C - E)

Núm/P de etiquetas de advertencia (sitios C - E)

C 098-1076

D 098-1085

E 098-0985

Metal Belt Guard

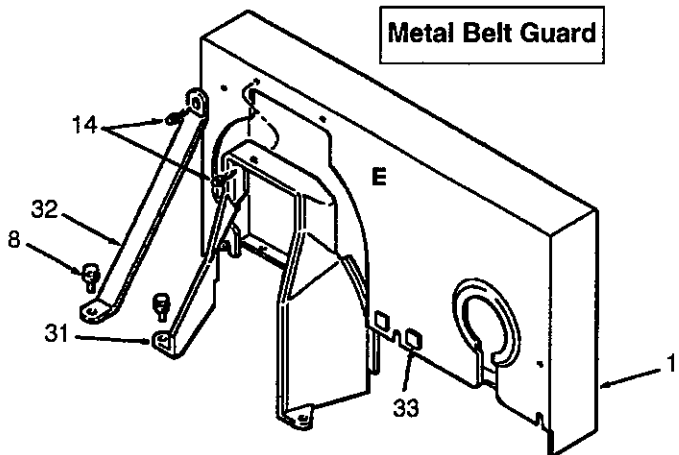

Polymer Belt Guard

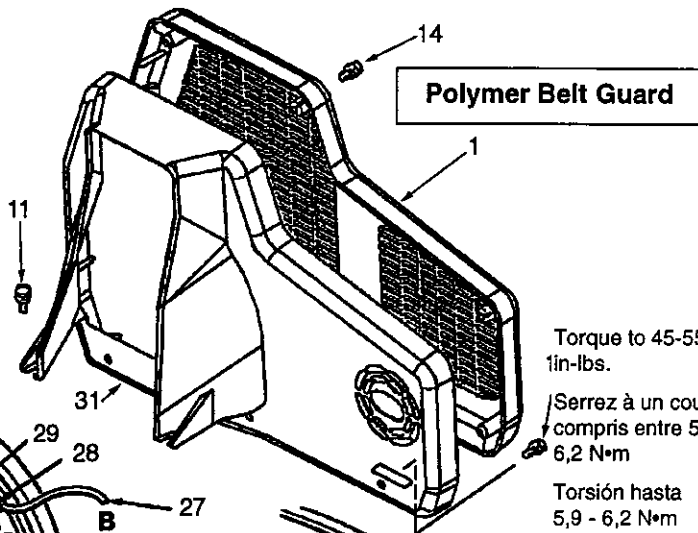

Torque to 45-55  
in-lbs.

Serrez à un couple  
compris entre 5,9 à  
6,2 N•m

Torsión hasta  
5,9 - 6,2 N•m

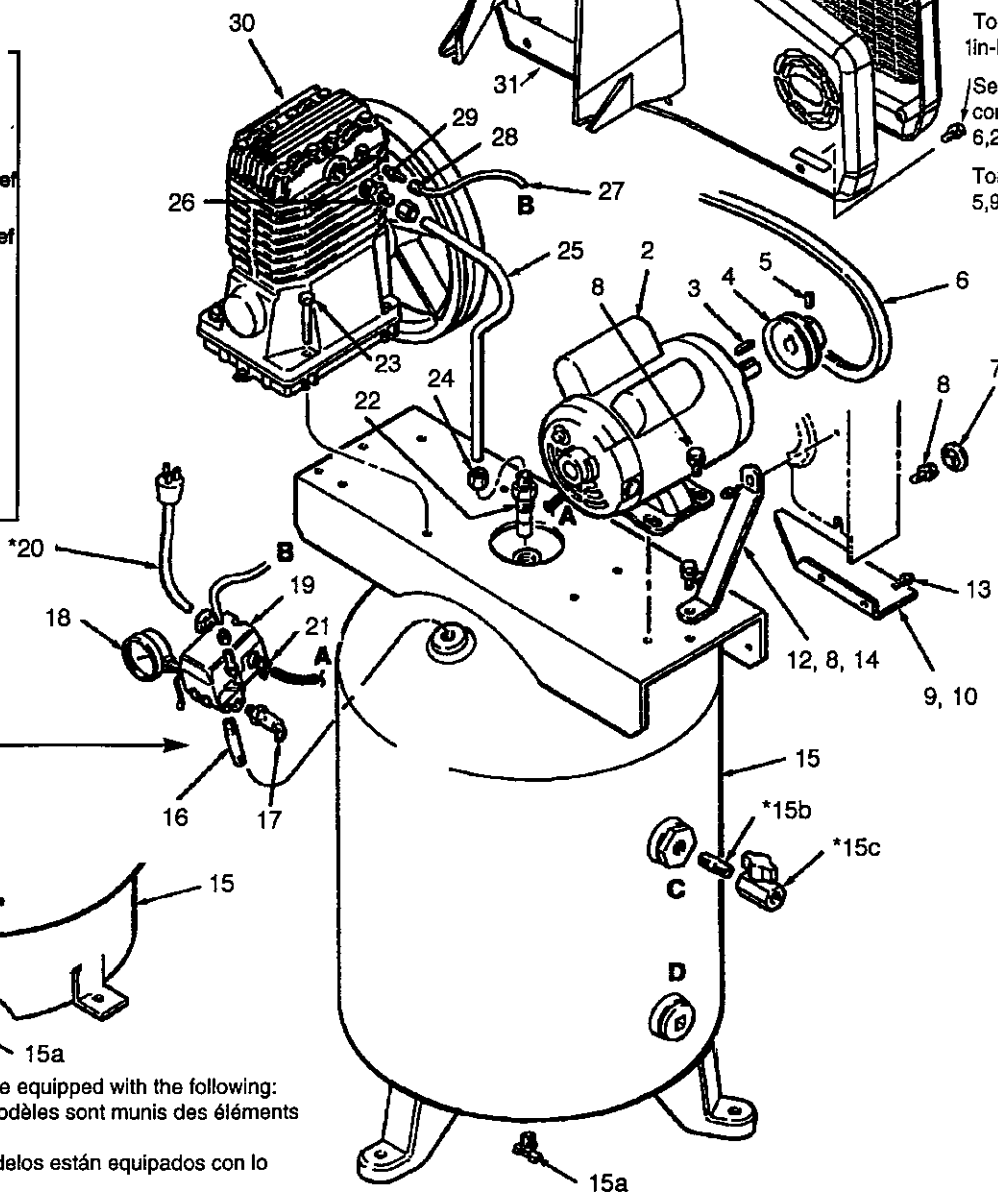
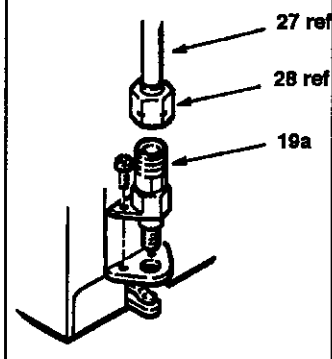

Bleeder valve detail

Description des pièces de la  
soupape de purge  
Detalle de la válvula de purga



\*NOTE: Not all models are equipped with the following:  
\*REMARQUE: Seuls certains modèles sont munis des éléments  
suivants:  
\*NOTA: No todos los modelos están equipados con lo  
siguiente:

- 15b Nipple .....Manchon fileté.....Niple
- 15c Valve .....Soupape.....Válvula
- 20 Power cord .....Cable.....Cordón

Item Art Art	Part No Nº / P Núm / P	Qty Qté Cant	 Description	 Description	 Descripción
1 ■		1	Belt guard, outer .....	Garant .....	Protector
2	160-0224	1	Motor .....	Moteur .....	Motor
2a	026-0188	1	Cord A-A .....	Câble .....	Cordón
3	146-0016	1	Key .....	Clé .....	Chaveta
4 ■		1	Pulley, A width .....	Poulie .....	Polea
5	061-0006	1	Setscrew .....	Vis D'arrêt .....	Tornillo fijador
6 ■		1	V-belt .....	Courroie .....	Correa
7 ■		3 or 4	Plug .....	Bouchon .....	Tapón
8	059-0012	11	Bolt .....	Boulon .....	Perno
9	125-0100		Underpan .....	Tôle inférieure .....	Bandeja inferior
10	125-0099	1	right side (shown)		
		1	Underpan .....	Tôle inférieure .....	Bandeja inferior
		1	Left side (not shown)		
11	059-0255	5	Screw .....	Vis .....	Tornillo
12	114-0006	1	Bracket .....	Support .....	Soporte
13 ■		4	Screw .....	Vis .....	Tornillo
14	061-0114	5	Plastite screw .....	Vis .....	Tornillo
15 ■		1	Tank assembly, Includes 15a .....	Ensemble du réservoir .....	Conjunto de tanque
15a	072-0001	1	Patcock .....	Robinet de purge .....	Llave de desagüe
15b ■ ▲		1	Nipple, close 3/8" NPT .....	Manchon fileté .....	Niple
15c ■ ▲		1	Valve .....	Soupape .....	Válvula
16	065-0005	1	Nipple .....	Manchon fileté .....	Niple
17	136-0037	1	Valve .....	Soupape .....	Válvula
18	032-0025	1	Gauge .....	Manomètre .....	Manómetro
19	034-0094	1	Switch .....	Interrupteur .....	Interruptor
19a	136-0013	1	Valve, bleeder .....	Soupape .....	Válvula
20 ■ ▲		1	Cord, power .....	Câble .....	Cordón
21 ■		1 or 2	Strain relief .....	Soulagement de traction .....	Aliviador de esfuerzo
22	031-0047	1	Valve, check .....	Soupape .....	Válvula
23	059-0010	4	Screw .....	Vis .....	Tornillo
24	058-0007	2	Nut .....	Écrou .....	Tuerca
25 ■		1	Tube, transfer .....	Tube .....	Tubo
26	068-0051	1	Connector .....	Connecteur .....	Conector
27 ■		1	Tube B-B .....	Tube .....	Tubo
			Also purchase 058-0017 qty 2	aussi être acheté	también debe comprar
28	058-0017	2	Nut .....	Écrou .....	Tuerca
29	068-0002	1	Connector .....	Connecteur .....	Conector
30 ■		1	Pump assy .....	Ensemble pompe .....	Conjunto de bomba
31 ■		1	Belt guard, inner .....	Garant .....	Protector
32	114-0129	1	Bracket .....	Support .....	Soporte
33	094-0010	2	Pad .....	Tampon .....	Almohadilla

Optional: Must be purchased separately (not shown)

Optionnel : Doit être acheté séparément (non illustré)

Opcional : Se debe comprar por separado (no se muestra)

094-0021 3 Pad .....

Tampon .....

Almohadilla

■ For exact replacement part numbers for your model, see next page.

Pour les numéros de pièces précis des pièces de rechange correspondant au modèle que vous possédez, consultez la page suivante.  
Para encontrar los números exactos de las partes de repuesto para su modelo, vea la página siguiente.

▲ These parts are included only with specific models; see next page.

Ces pièces ne sont comprises qu'avec certains modèles; consultez la page suivante.  
Estas partes se incluyen únicamente con modelos específicos; vea la página siguiente.

Part Number	MODEL NUMBER												
	BL6006016	CL6006016	CL6506016	GL6506016.01	ML6006016	ML6506016	ML6506016.02	QL6506016	CL5006016	ML5006016	TL5004416	DL5006016	IL5006016
1	125-0151	•	•	•	•	•	•	•	•	•	•	•	•
	142-0049												•
4	006-0018											•	•
	006-0108	•	•	•	•	•	•	•	•	•	•	•	•
6	007-0038	•	•	•	•	•	•	•	•	•	•	•	•
	007-0048								•	•	•	•	•
7	093-0005	4	4	4	4	4	4	4	4	4	3	4	4
	061-0056	4	4	4	4	4	4	4	4	4		4	4
13	061-0005										4		
	021-0205										•		
15	153-0032												•
	021-0206											•	
15b	065-0032												•
15c	073-0007												•
20	026-0187										•		
21	071-0002	1	1	1	1	1	1	1	1	1	2	1	1
	145-0290												•
25	145-0313	•	•	•	•	•	•	•	•	•	•	•	•
	145-0291										•		
	145-0312						•	•	•				
27	145-0084	•	•	•	•	•	•	•	•	•	•	•	•
	145-0192						•	•	•	•	•	•	•
30	040-0193	•	•	•	•	•	•	•	•	•	•	•	•
	040-0197						•	•	•	•	•	•	•
30	125-0152	•	•	•	•	•	•	•	•	•	•	•	•
	142-0039												•

*Fix Parts Matrix. Part #'s Not Specified*  
*Run BOM + look at drawings to verify*

REPLACEMENT PARTS FOR MOTORS Pièces de rechange pour moteurs Partes de repuesto para los motores	Magne Tek Motor Only	GE Motor Only	Emerson Motor Only
Start Capacitor, Black Le condensateur de démarrage, noir La Condensador de arranque, negro	166-0055	166-0080	166-0092
Start Capacitor Cover Le couvercle de démarrage du condensateur La tapa de arranque la condensador	166-0029	166-0082	166-0093
Run Capacitor, Silver Le condensateur de marche, argenté La condensador de funcionar, plata	166-0052	166-0079	166-0094
Run Capacitor Cover Le couvercle de marche du condensateur La tapa de funcionar la condensador	166-0028	166-0081	166-0095
Overload Protector Protecteur contre la surcharge Protector contra sobrecarga	166-0003	NA	166-0096

**WIRING OF REPLACEMENT MOTOR**  
**Câblage de rechange pour le moteur**  
**Instalación de repuesto para el motor**

- A** Loosen 2 screws to remove plate.  
 Desserrez les deux vis pour retirer la plaque.  
 Afloje 2 tornillos para retirar la placa referencia.

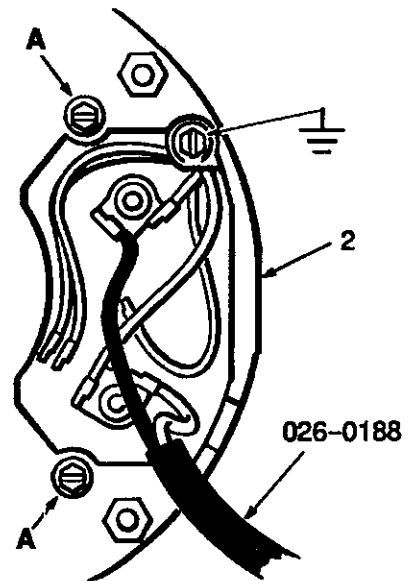

## Item 2 Ring set 054-0112 from pages 6 & 7

**IMPORTANT:** Rings must be assembled with colored stripes in the position shown below and in the following numerical sequence:

**IMPORTANT:** Assemblez les segments en veillant à ce que les rayures colorées soient à la position représentée ci-dessous et conformément à la séquence numérique suivante:

**IMPORTANTE:** Los anillos deben instalarse con las rayas coloreadas en la posición indicada abajo y en la secuencia numerica siguiente:

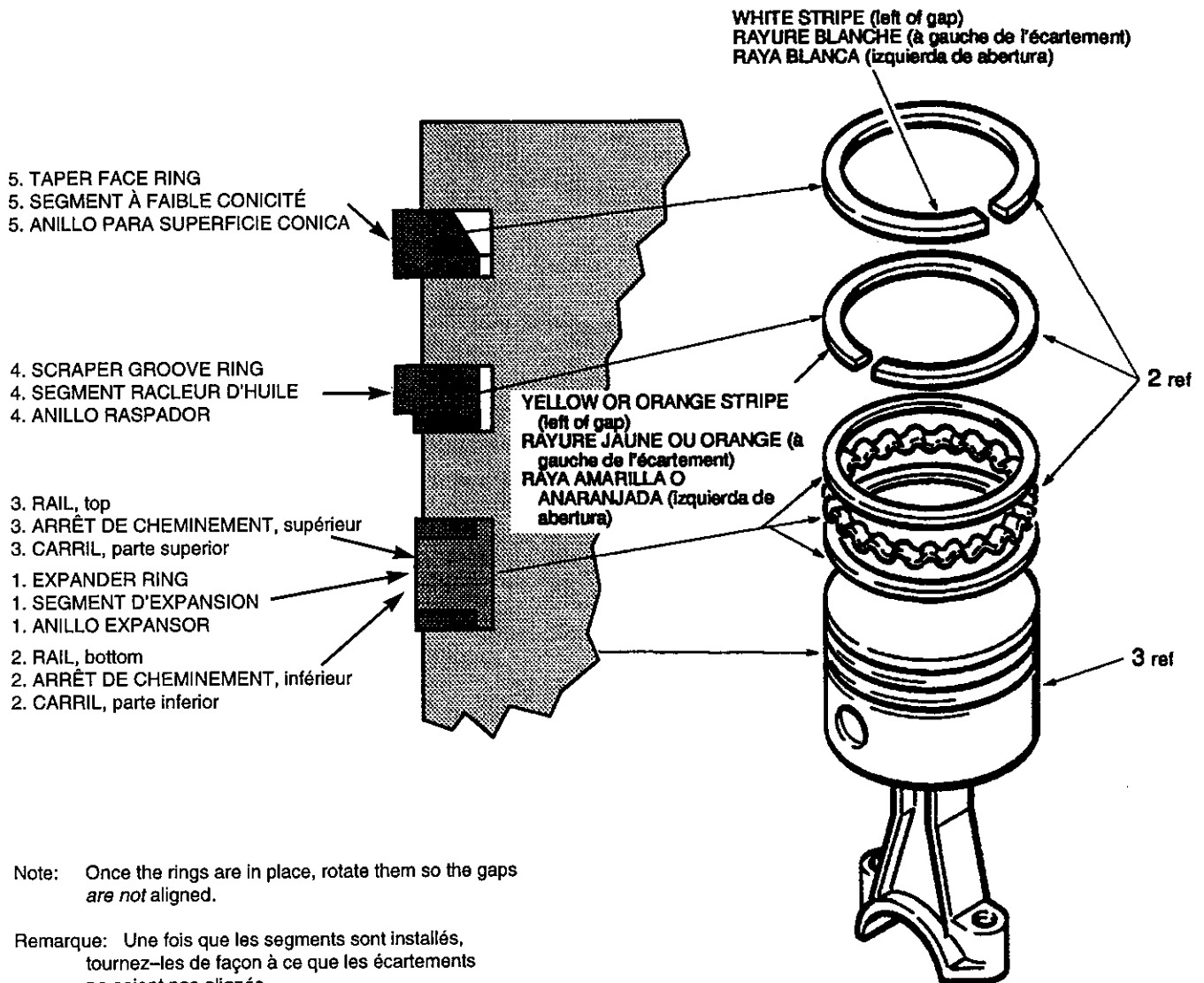

165 Pump Assy

Head Bolt Torque Sequence  
 Séquence De Serrage Des  
 Boulons À Tête  
 Secuencia De Los Pernos  
 Del Cabeza



Sequence #'s 1, 2, 3, 4, 5, 6, 7 & 8  
 Torque to 220-300 in-lbs  
 Séquence De Serrage Des Boulons 1, 2, 3,  
 4, 5, 6, 7 et 8  
 serrez à un couple compris entre 24,6 à 33,9  
 N•m

# De Secuencia 1, 2, 3, 4, 5, 6, 7 y 8  
 Torsión hasta 24,6 - 33,9 N•m

Pump Specifications  
 Weight-39 lbs.  
 Oil Capacity (approx.)-22 oz.  
 Min. RPM-700  
 Max. RPM-1200  
 Max. Ambient Temp-104°F (40°C)

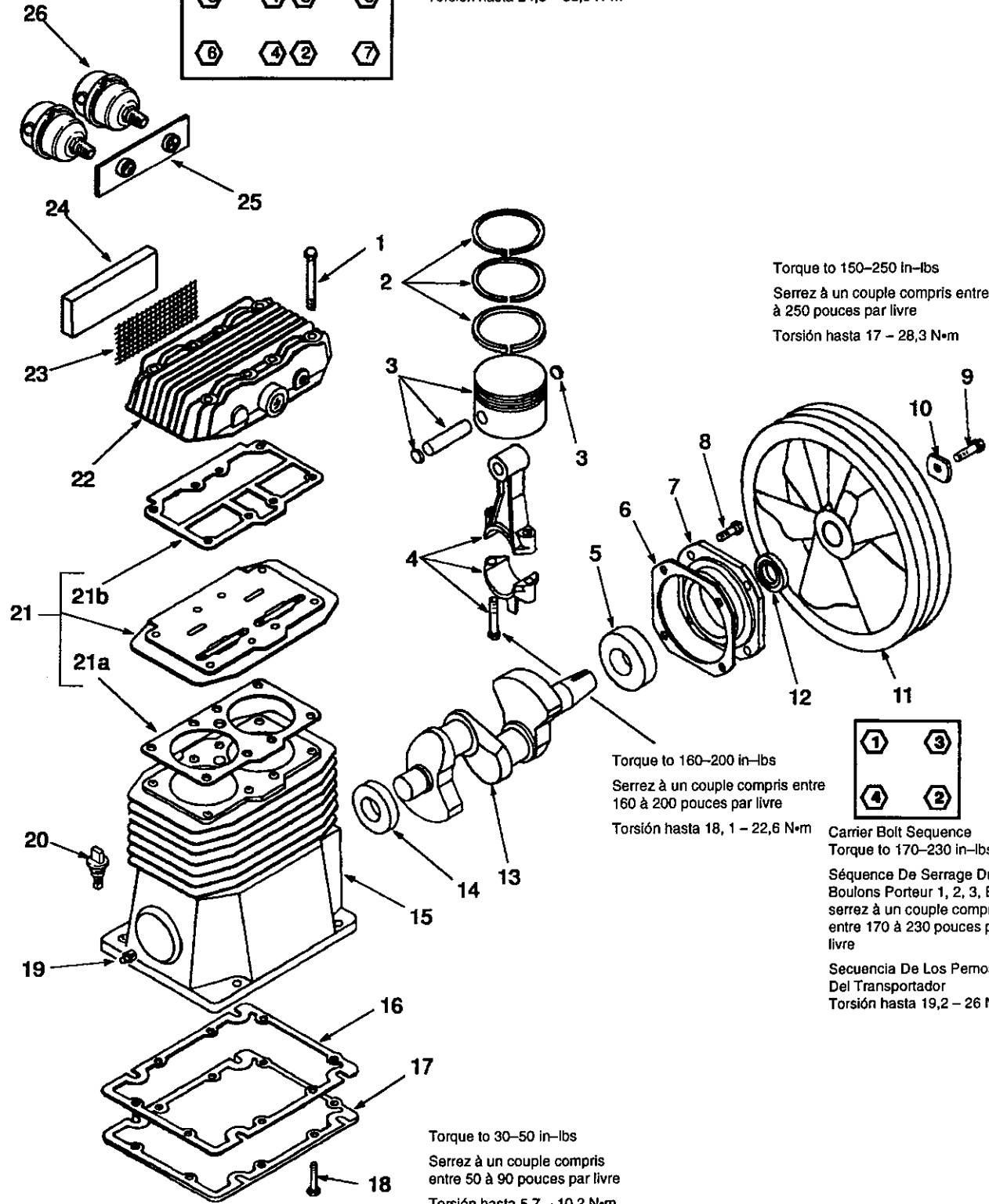

Torque to 150-250 in-lbs  
 Serrez à un couple compris entre 150  
 à 250 pouces par livre  
 Torsión hasta 17 - 28,3 N•m

Torque to 160-200 in-lbs  
 Serrez à un couple compris entre  
 160 à 200 pouces par livre  
 Torsión hasta 18,1 - 22,6 N•m

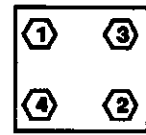



Carrier Bolt Sequence  
 Torque to 170-230 in-lbs  
 Séquence De Serrage Du  
 Boulons Porteur 1, 2, 3, ET 4  
 serrez à un couple compris  
 entre 170 à 230 pouces par  
 livre

Secuencia De Los Pernos  
 Del Transportador  
 Torsión hasta 19,2 - 26 N•m

Torque to 30-50 in-lbs  
 Serrez à un couple compris  
 entre 50 à 90 pouces par livre  
 Torsión hasta 5,7 - 10,2 N•m

## 165 Pump Assy – Ensemble du pompe – Conjunto de bomba

Item Art Art	Part No N° / P Núm / P	Qty Qté Cant	 Description	 Description	 Descripción			
1	059-0144	8	Screw, 5/16-18 x 2.50" lg.....	Vis .....	Tornillo			
2	054-0112	1	Ring set, see page 5.....	Jeu d'anneaux.....	Juego de anillos			
3	048-0065	2	Piston assembly.....	Ensemble du piston.....	Conjunto de pistón			
4	047-0069	2	Rod, 130 pump.....	Tige .....	Varilla			
	047-0070	or	Rod, 165 pump.....	Tige .....	Varilla			
5	051-0043	1	Bearing.....	Roulement.....	Cojinete			
6	046-0149	1	Gasket.....	Joint.....	Empaquetadura			
7	045-0043	1	Carrier.....	Support.....	Portador			
8	059-0143	4	Screw, 5/16-18 x .87" lg.....	Vis .....	Tornillo			
<b>must be purchased separately</b>			<b>doit être acheté séparément</b>			<b>se debe comprar por separado</b>		
9	059-0002	1	Screw, 5/16-18 x 1.0" lg.....	Vis .....	Tornillo			
10	060-0053	1	Washer.....	Rondelle.....	Arandela			
11	044-0039	1	Flywheel, 12" A width.....	Volant-moteur, A.....	Volante, A			
12	046-0161	1	Seal.....	Joint.....	Sello			
13	053-0041	1	Crankshaft, 130 pump.....	Vilebrequin.....	Cigüeñal			
	053-0043	or	Crankshaft, 165 pump.....	Vilebrequin.....	Cigüeñal			
14	051-0081	1	Bearing.....	Roulement.....	Cojinete			
15	049-0043	1	Crankcase.....	Carter.....	Cárter			
16	046-0263	1	Gasket.....	Joint.....	Empaquetadura			
17	077-0148	1	Base.....	Base.....	Base			
18	061-0111	13	Screw, #10 - 24 x 1/2".....	Vis .....	Tornillo			
19	061-0112	1	Plug, 5/16 - 18.....	Bouchon.....	Tapón			
20	056-0019	1	Dipstick.....	Jauge de niveau.....	Varilla de aceite			
21	043-0142	1	Plate, assy, includes 21a-21b.....	Ensemble du plaque.....	Conjunto de placa			
21a	046-0152	1	Gasket.....	Joint.....	Empaquetadura			
21b	046-0151	1	Gasket.....	Joint.....	Empaquetadura			
22	042-0068	1	Head.....	Tête.....	Cabezal			
23 ■	118-0023	1	Screen.....	Crépine.....	Malla			
24 ■	019-0052	1	Filter, felt.....	Filtre.....	Filtro			
25 ■	019-0096	1	Plate.....	Plaque.....	Placa			
26 ■	019-0165	2	Filter, canister includes 26a.....	Filtre.....	Filtro			
26a	019-0166	2	Element.....	Élément.....	Elemento			

## Available Service Kits

Part No	Description	Description	Descripción
046-0159	Gaskets, complete set.....	Joints, jeu complet.....	Juntas, conjunto completo
165-0083	Overhaul kit, felt filter model includes ring and gasket sets, valve plate assembly and filter element	Jeu de pièces de réparation, le modèle muni d'un filtre en feutre comprend des jeux de bagues et de joints, l'assemblage de la plaque et de joints, l'assemblage de la plaque de la soupape et l'élément du filtre	Juego de acondicionamiento, modelo de filtro de fieltro incluye conjuntos de anillo y junta, conjunto de la placa de la válvula y elemento del filtro
165-0055	Overhaul kit, canister filter model includes ring and gasket sets, and valve plate assembly	Jeu de pièces de réparation..... le modèle muni d'un filtre en boîte comprend des jeux de bagues et de joints, l'assemblage de la plaque et de joints, l'assemblage de la plaque de la soupape	Juego de acondicionamiento, modelo de filtro de lata incluye conjuntos de anillo y junta, conjunto de la válvula

- Felt filter models include items 23 and 24. Canister filter models include items 25 and 26.  
Les modèles muni d'un filtre en feutre comprends art. 23 et 24. Les modèles de filtre en boîte comprends art. 25 et 26.  
Los modelos de filtro de fieltro de incluyen art. 23 y 24. Los modelos de filtro de lata de incluyen art. 25 y 26.