



-  **Oilless, Single-Stage, Direct-Drive, Electric Air Compressors**
-  **Sans l'huile, d'un seule étape, à prise directe, compresseur d'air électrique**
-  **Sin aceite, de una sola etapa, de mando directo, compresor de aire eléctrico**



**Specification Chart** \_\_\_\_\_ **Tableau des spécifications** \_\_\_\_\_ **Cuadro de especificaciones**

MODEL NO. (MODÈLE) (MODELO)	H.P. (CV)	TANK CAPACITY GALLONS (CAPACITÉ DU RÉSERVOIR - LITRES) (CAPACIDAD DEL TANQUE - LITROS)	VOLTAGE/ AMPS/ PHASE (TENSION/ AMPS/ PHASE) (VOLTAJE/ AMP/ FASE)	CFM (l/min) @ 40 PSI (2,8 bar)	CFM (l/min) @ 90 PSI (6,3 bar)	KICK-IN PRESSURE (PRESSION D'OUVERTURE) (PRESION DE CONEXION)	KICK-OUT PRESSURE (PRESSION DE FERM.) (PRESION DE DESCONEXION)
*10C075P1D1	1	7.5 (28)	115/15/1	4.0 (113)	2.7 (76)	90 (6,2 bar)	120 (8,3 bar)
M02FL100-7.5				8.2 (235)	6.2 (180)		
*25C075P1D1	2.5	7.5 (28)		8.2 (232)	6.2 (175)		
M05F250-7.5				8.2 (235)	6.2 (180)		
*2511				8.3 (235)	6.3 (180)		
*311	3	11 (42)		8.3 (235)	6.3 (180)		
*30C110P1D1				8.6 (243)	6.7 (189)		
*35C110P1D1	3.5	20 (75)		8.6 (243)	6.7 (189)		
*3511				9.0 (255)	7.2 (204)		
M07F350-20				8.8 (249)	6.9 (195)		
*40C075P1D1	4	7.5 (28)		8.8 (249)	6.9 (195)		
*40C110P1D1		11 (42)		9.0 (255)	7.2 (204)		
*40C200P1D1		20 (76)		8.8 (249)	6.9 (195)		
*40C250P1D1		25 (95)		8.8 (249)	6.9 (195)		
*45L250P1D1	4.5	25 (95)		9.0 (255)	7.2 (204)		
*40L440V1D1	4	44 (166)		8.8 (249)	6.9 (195)		

\* Prefix letter-Lettre du préfixe-Letra de prefijo

**?** Questions? See back page. \_\_\_\_\_ Questions ? Consultez la page final. \_\_\_\_\_ ¿Preguntas? Vea la página final.

Fix of warning labels (locations C - D)  
Nº/ P des étiquettes de avertissement (emplacements C - D)  
Núm/P de etiquetas de advertencia (sitios C - D)

- C 098-0984
- D 098-1085

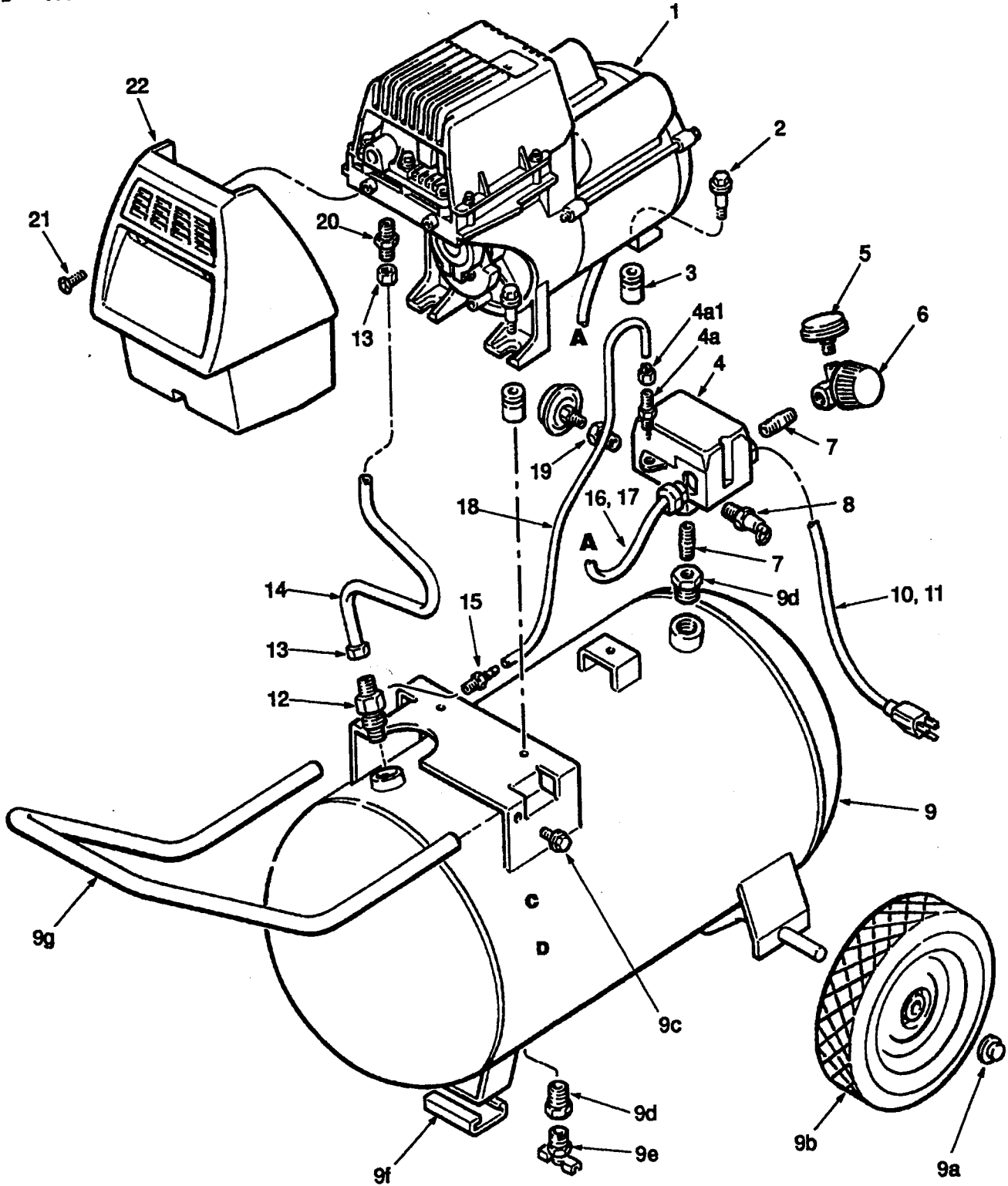

PN of warning labels (locations C - E)

Nº/ P des étiquettes de avertissement (emplacements C - E)

Núm/P de etiquetas de advertencia (sitios C - E)

C 098-0984

D 098-1085

E 098-2099

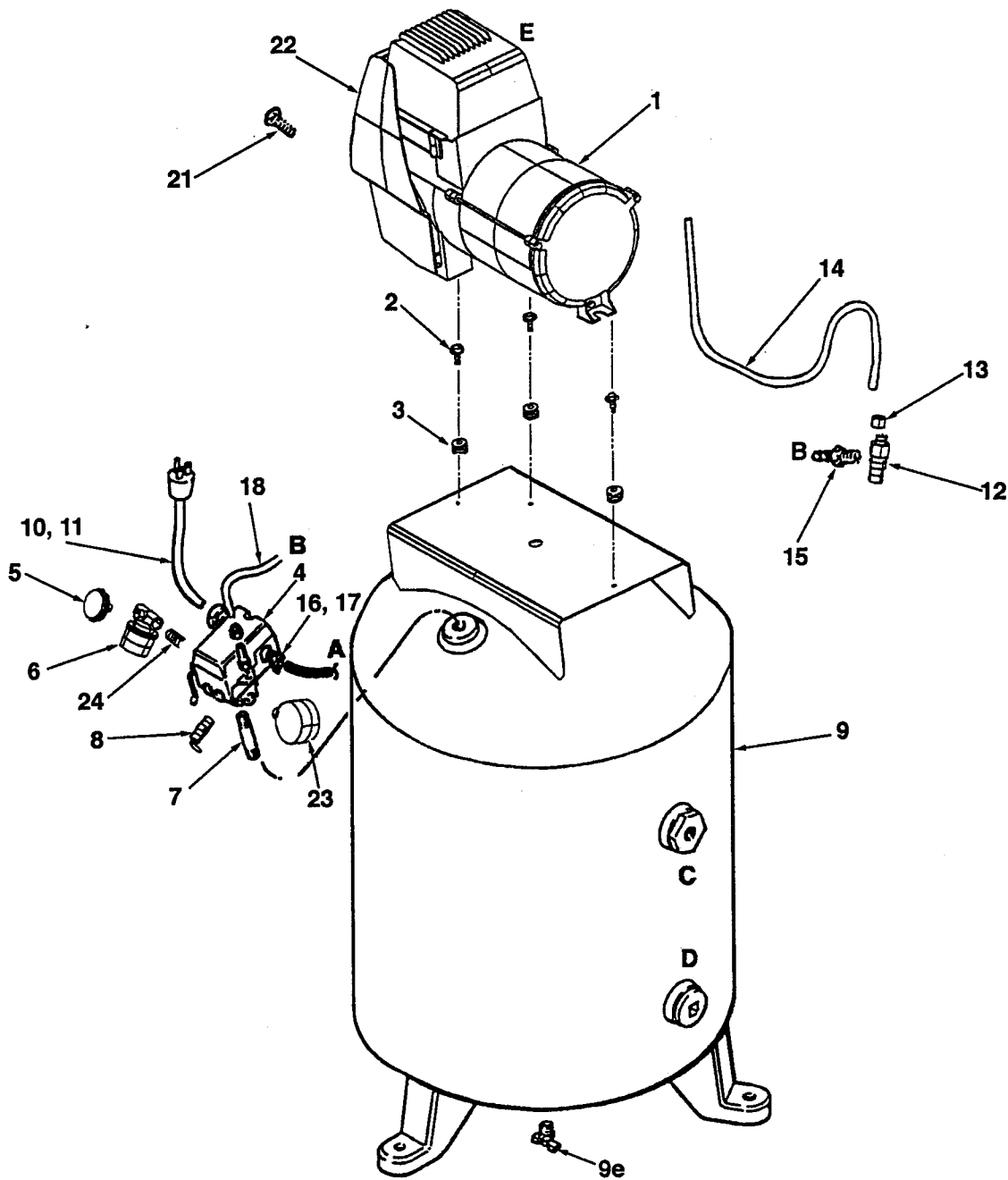

	Part No Nº / P Núm / P	Qty Qté Cant	Description	Description	Descripción
1	040-0242	1	4.5 H.P. Pump/motor assy.....	Ensemble pompe/moteur.....	Conjunto de bomba/motor
	040-0287	1	1 H.P. Pump/motor assy.....	Ensemble pompe/moteur.....	Conjunto de bomba/motor
2	059-0221	3	Bolt, shoulder, 1/4-28.....	Boulon.....	Perno
3	093-0019	3	Grommet.....	Oeillet.....	Arandela de cabo
4	034-0096	1	Switch, pressure.....	Interrupteur.....	Manómetro
			<i>includes item 4a</i>	<i>inclut les élément 4a</i>	<i>incluye los artículo 4a</i>
▼	034-0094	1	Switch, pressure.....	Interrupteur.....	Manómetro
			<i>includes item 4a</i>	<i>inclut les élément 4a</i>	<i>incluye los artículo 4a</i>
4a	136-0013	1	Valve, bleeder, includes 4a1.....	Soupape.....	Válvula
4a1	058-0017	1	Nut, 1/4" O.D. tube.....	Écrou.....	Tuerca
5	032-0052	2	Gauge, 200 PSI.....	Manomètre.....	Manómetro
6	019-0167	1	Regulator.....	Régulateur.....	Regulador
▼	019-0182	1	Regulator.....	Régulateur.....	Regulador
7	065-0033	2	Nipple, 1/4 NPT x 1.50" lg.....	Manchon fileté.....	Niple
8	136-0037	1	Valve, 135 PSI, 1/4 NPT ASME.....	Soupape.....	Válvula
9	150-0045	1	Tank assy, includes 9a-9g.....	Ensemble du réservoir.....	Conjunto de tanque
			7.5 gallon	28 litres	28 litros
or	127-0039	1	Tank assy, includes 9a-9g.....	Ensemble du réservoir.....	Conjunto de tanque
			11 gallon	42 litres	42 litros
or	130-0045	1	Tank assy, includes 9a-9g.....	Ensemble du réservoir.....	Conjunto de tanque
			20 gallon	76 litres	76 litros
or	131-0023	1	Tank assy, includes 9e.....	Ensemble du réservoir.....	Conjunto de tanque
			25 gallon	95 litres	95 litros
▼	021-0199	1	Tank assy, Includes 9a-9g.....	Ensemble du réservoir.....	Conjunto de tanque
			44 gallon	167 litres	167 litros
9a	033-0001	2	Hubcap.....	Chapeau de moyeu.....	Tapacubo
*	033-0002	2	Hubcap (10" wheel).....	Chapeau de moyeu.....	Tapacubo
9b	095-0010	2	Wheel, 8".....	Roue.....	Rueda
*	095-0014	2	Wheel, 10".....	Roue.....	Rueda
▲	095-0016	2	Wheel, 7".....	Roue.....	Rueda
	059-0216	2	Screw, 1/4-20 x .5" lg.....	Vis.....	Tornillo
			w/serrated washer		
9d	063-0006	2	Bushing, 3/4 NPT x 1/4 NPT.....	Bague.....	Buje
9e	072-0001	1	Petcock.....	Robinet de décompression.....	Llave de desagüe
9f	094-0015	1	Pad.....	Tampon.....	Almohadilla
9g	112-0002	1	Handle.....	Poignée.....	Manija
10	026-0030	1	Cord, power.....	Câble.....	Cordón
11	071-0002	1	Strain relief.....	Soulagement de traction.....	Aliviador de esfuerzo
12	031-0037	1	Valve, check.....	Soupape.....	Válvula
			1/2 NPT x 3/8" O.D. tube		
13	058-0007	2	Nut, 3/8" O.D. tube.....	Écrou.....	Tuerca
14	145-0179	1	Tube, transfer.....	Tube.....	Tubo
			<i>Also purchase 058-0007 qty 2</i>	<i>también être acheté</i>	<i>aussi debe comprar</i>
▼	145-0307	1	Tube, transfer.....	Tube.....	Tubo
15	068-0506	1	Connector, 1/8 NPT x 1/4 barb.....	Connecteur.....	Conector
16	026-0233	1	Cord, interconnect.....	Câble.....	Cordón
17	071-0008	1	Strain relief.....	Soulagement de traction.....	Aliviador de esfuerzo
18	145-0253	1	Tube, bleeder.....	Tube.....	Tubo
			<i>Also purchase 058-0017 qty 1</i>	<i>también être acheté</i>	<i>aussi debe comprar</i>
▼	145-0308	1	Tube, bleeder.....	Tube.....	Tubo
19	063-0023	1	Bushing, 1/4 NPT x 1/8 NPT.....	Bague.....	Buje
20	068-0017	1	Connector.....	Connecteur.....	Conector
			1/4 NPT x 3/8" O.D. tube		
21	061-0108	3	Screw, #8-32 x 7/16" lg.....	Vis.....	Tornillo
22	142-0091	1	Shroud.....	Enveloppe.....	Guardera
23	032-0052	1	Gauge.....	Manomètre.....	Manómetro
24	065-0005	1	Nipple 1/4" x 2 1/2".....	Manchon fileté.....	Niple

**Bleeder valve detail**  
Description des pièces de la soupape de purge  
Detalle de la válvula de purga

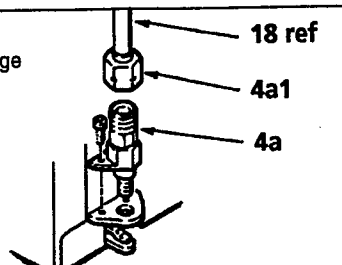

- 2.5, 3, 3.5 & 4 H.P. replacement motors are not available for service. Replace with 4.5 H.P. motor assembly.
- ▲ 7" wheel for 7.5 gal tank only.
- 1 H.P. replacement motor.
- \* 10" wheel for 20 & 25 gallon tanks only.
- ▼ Used on model B40L440V1D101

**Pump specifications**  
Weight - 34 Lbs Approx.  
Max Rpm - 3500

**Spécifications de la pompe**  
Poids - 15,4 Kg  
Régime maximum - 3500 Tr/Min

**Especificaciones de la bomba**  
Peso - 15,4 Kg  
Rpm Max - 3500

**040-0242 PUMP/MOTOR ASSEMBLY**  
or  
**040-0287 (Ensemble pompe/moteur)**  
**(Conjunto de bomba/motor)**

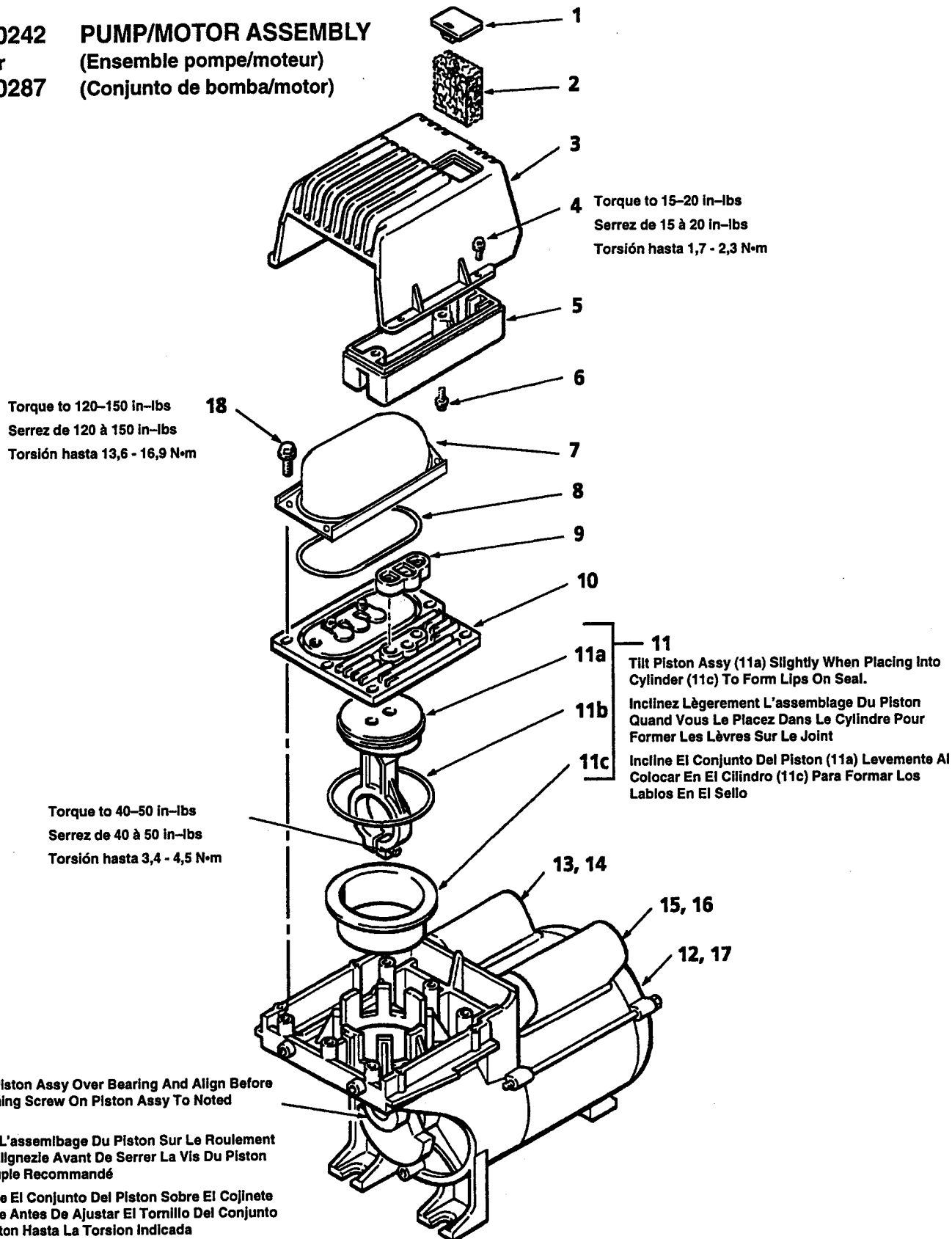

**ARTS LIST**

**LISTE DE PIÈCES**

**LISTA DE LAS PIEZAS**

Item #	Part No Nº / P Núm / P	Qty Qté Cant	Description	Description	Descripción
1	077-0118	1	Cover .....	Couvercle .....	Tapa
2	019-0152	1	Filter .....	Filtre .....	Filtro
3	077-0136	1	Cover .....	Couvercle .....	Tapa
4	061-0061	6	Screw, #8 - 32 x .38" lg.....	Vis .....	Tornillo
5	019-0151	1	Manifold .....	Collecteur .....	Múltiple
6	061-0060	2	Screw, #8 - 32 x .75" lg.....	Vis .....	Tornillo
7	117-0011	1	Manifold .....	Collecteur .....	Múltiple
8	054-0157	1	O-ring.....	Joint torique.....	Anillo tórico
9	046-0231	1	Seal.....	Joint.....	Sello
10	<del>043-0151</del>	1	Valve plate assembly.....	Ensemble de la plaque de soupape	Conjunto de placa de válvula
11	<del>043-0165</del> 048-0074	1	Piston & cylinder assy..... <i>includes items 11a-11c</i>	Ensemble du piston..... et du cylindre <i>inclut les éléments 11a-11c</i>	Conjunto de cilindro y pistón <i>incluye los artículos 11a-11c</i>
11a	NA	1	Piston assy .....	Ensemble du piston.....	Conjunto de pistón
11b	054-0158	1	O-ring.....	Joint torique.....	Anillo tórico
11c	NA	1	Cylinder.....	Cylindre .....	Cilindro
12	NA	1	Motor assy .....	Ensemble du moteur .....	Conjunto de motor
			must be purchased as complete pump/motor assy	vendu en une seule ensemble pompe/moteur	se debe comprar como un conjunto completo
<b>(13 thru 18 used on 2.5 thru 4.5 H.P. motors only)</b>					
13	166-0088	1	Capacitor, start, black.....	Condensateur.....	Condensador
14	166-0025	1	Cover .....	Couvercle .....	Tapa
15	166-0018	1	Capacitor, run, silver.....	Condensateur.....	Condensador
16	166-0028	1	Cover .....	Couvercle .....	Tapa
17	077-0137	1	Cover, terminal .....	Couvercle .....	Tapa
18	061-0062	6	Screw, 1/4 - 20 x 1.12" lg.....	Vis .....	Tornillo

**Service Kits Available - must be purchased separately**  
**x De Pièces D'entretien Disponibles - doit être acheté séparément**  
 **Kits De Servicio Disponibles - se debe comprar por separado**

046-0234

Seal kit.....  
*includes items*  
8, 9 & 11b

Jeu de joints .....

Juego de sellos  
*inclut les éléments*  
8, 9 & 11b  
*incluye los artículos*  
8, 9 & 11b