

# Air Compressor Parts Manual

200-1944

Rev. D

## "F" SERIES 2, 3 & 3 1/2 H.P. PORTABLE ELECTRIC OILLESS SINGLE STAGE DIRECT DRIVE

### MODELS:

07F350

 04FL200,  
06FL300, 07FL350

 04FC200, 07FC350

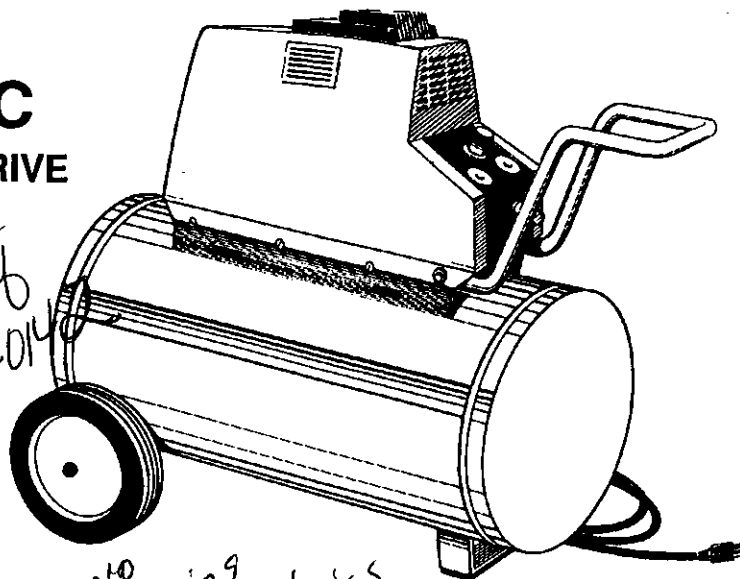

*166-0040  
capacitor  
no*

*165-014*

*No Rewinding  
Essencdrics  
- must whole unit*

### SPECIFICATION CHART

MODEL NO.	H.P.	AIR RECEIVER TANK CAPACITY GALLONS	VOLTAGE/ AMPS/ PHASE	SCFM Displ @ 40 PSI	SCFM Displ @ 90 PSI	APPROX. KICK-IN PRESSURE	APPROX. KICK-OUT PRESSURE
07F350-13	3 1/2	13	115 / 15 / 1	8.6	6.7	90	120
07F350-20		20					
04FL200-13	2	13	115 / 15 / 1	6.7	5.3	90	120
04FL200-20 (A)		20 (A.S.M.E.)					
06FL300-20	3	20	115 / 15 / 1	8.2	6.2	90	120
07FL350-13A	3 1/2	13 A.S.M.E.					
07FL350-20 (A)		20 (A.S.M.E.)					
07FL350-30A		30 A.S.M.E.		8.6	6.7		
04FC200-10	2	10	115 / 15 / 1	6.7	5.3	90	120
04FC200-20A		20 A.S.M.E.					
07FC350-20A	3 1/2	20 A.S.M.E.		8.6	6.7		

In the event you should have a question, or a concern, with the air compressor, **DO NOT** return it to the store where you purchased it. Most problems and concerns can be taken care of on the telephone!

Simply call (800) 544-5145 (Toll Free) and discuss the concern with our trained Customer Service Department. Should you not be able to reach us at the above number, please check the Service Center Listing included with your instruction manual and call the Service Center nearest you for assistance.

**CAUTION:** Read the operator's manual carefully before attempting to operate or service this unit! FAILURE TO COMPLY WITH INSTRUCTIONS COULD RESULT IN: VOIDING OF YOUR WARRANTY, PERSONAL INJURY AND / OR PROPERTY DAMAGE! This Air Compressor is precision built from the finest materials and with proper care and maintenance will perform efficiently.

# PARTS DRAWING

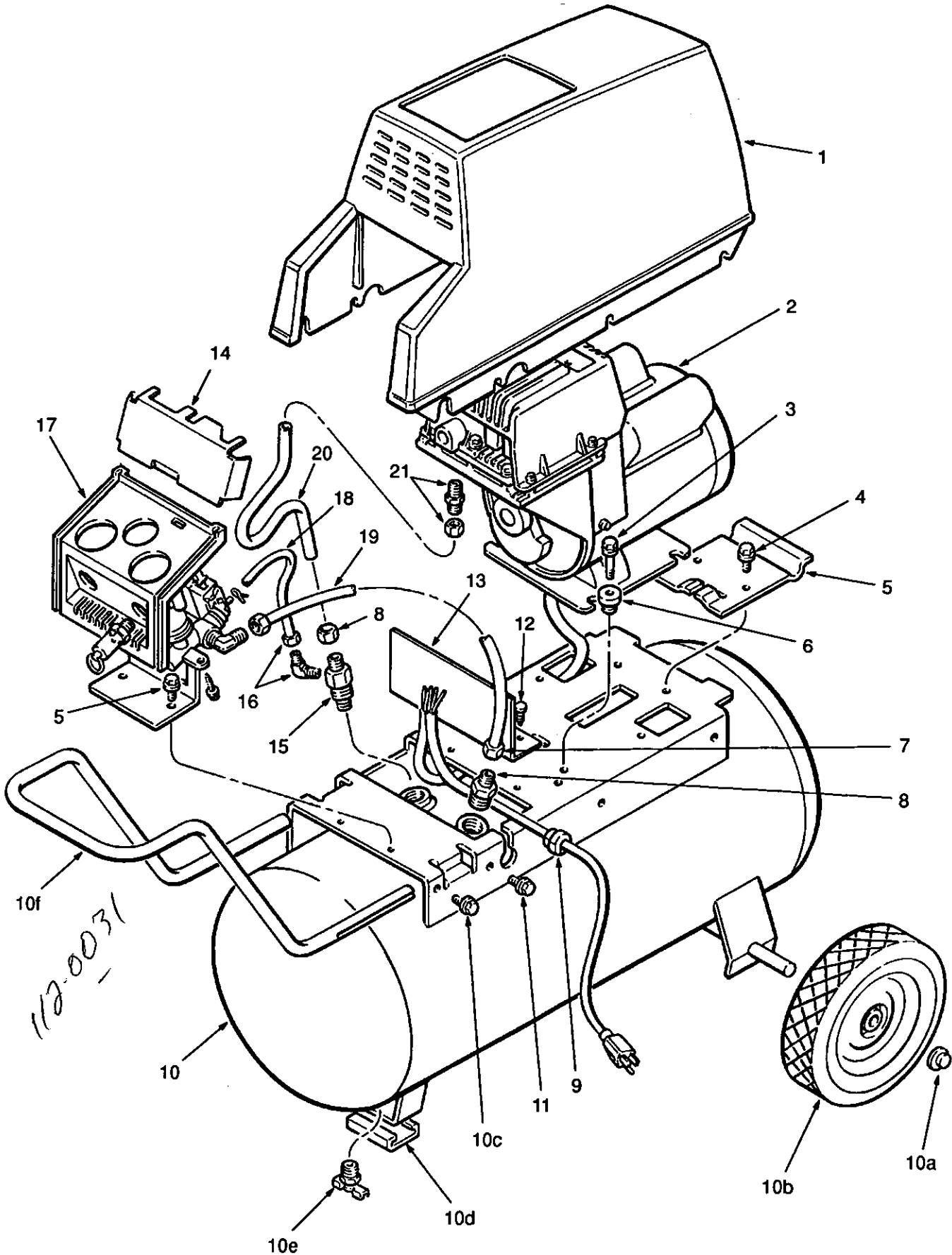

# PARTS DRAWING & LIST

ITEM	PART NO	DESCRIPTION	QTY
1	142-0072	SHROUD	1
2	040-0172	2 HP PUMP/MOTOR ASSY see page 7 for parts	
	or		
	NA	3 HP PUMP/MOTOR ASSY for service, replace with 3 1/2 HP	
	or		
	040-0174	3 1/2 HP PUMP/MOTOR ASSY see page 7 for parts	
3	059-0221	SCREW, shoulder, 1/4"-28 x 3/4"	2
4	059-0216	SCREW, 1/4"-20 x 1/2" lg w/serrated washer	4
5	112-0048	HANDLE, platform	1
6	093-0018	GROMMET	4
7	058-0007	NUT, compression	2
8	068-0008	CHECK VALVE 1/2" NPT x 3/8" O.D. tube	1
9	071-0008	BUSHING, strain relief "F" or "FL" series	
	or		
	071-0009	BUSHING, strain relief "FC" series	1
10	127-0034	TANK ASSY, 10 gallon includes items 10a-10f	
	or		
	128-0024	TANK ASSY, 13 gallon includes items 10a-10f	
	or		
	128-0026	TANK ASSY, 13 gallon A.S.M.E. includes items 10a-10f	
	or		
	130-0028	TANK ASSY, 20 gallon includes items 10a-10f	
	or		
	130-0029	TANK ASSY, 20 gallon A.S.M.E. includes items 10a-10f	1
	or		
	131-0017	TANK ASSY, 30 gallon A.S.M.E. includes items 10a-10f	1
10a	033-0001	.HUB CAP, 10 & 13 gallon tanks	
	or		
	033-0002	.HUB CAP, 20 & 30 gallon tanks	2
10b	095-0010	.WHEEL, 8" for 10 & 13 gal. tanks	
	or		
	095-0014	.WHEEL, 10" for 20 & 30 gal. tanks	2
10c	059-0216	.BOLT, 1/4"-20 x 1/2" lg w/serrated washer	2
10d	072-0001	.PETCOCK, 1/4" NPT	1
10e	094-0015	.PAD, vibration	1
10f	112-0049	.HANDLE	1
11	059-0215	SCREW, 1/4"-20 x 1/2" lg	6
12	093-0015	FASTENER, ratchet for 3 & 3 1/2 HP only	2
13	056-0036	BAFFLE, platform for 3 & 3 1/2 HP only	1
14	056-0033	BAFFLE	1
15	031-0037	VALVE, check 1/2" NPT x 3/8" O.D. tube	1
16	064-0003	ELBOW, 90° brass	1
17	NA	MANIFOLD/SWITCH ASSY "F" or "FL" series, see pg. 4 for parts	
	or		
	NA	MANIFOLD/SWITCH ASSY "FC" series, see page 5 for parts	1

## "F" Series OILLESS

**MODEL 07F350-13** includes items 1-21  
3 1/2 HP with 13 gal portable non-code tank

**MODEL 07F350-20** includes items 1-23  
3 1/2 HP with 20 gal portable non-code tank

## "FL" Series OILLESS



**MODEL 04FL200-13** includes items 1-11, 14-21  
2 HP with 13 gal portable non-code tank

**MODEL 04FL200-20** includes items 1-11, 14-23  
2 HP with 20 gal portable non-code tank

**MODEL 04FL200-20A** includes items 1-11, 14-23  
2 HP with 20 gal portable A.S.M.E. tank

**MODEL 06FL300-20** includes items 1-23  
3 HP with 20 gal portable non-code tank

**MODEL 07FL350-13A** includes items 1-21  
3 1/2 HP with 13 gal portable A.S.M.E. tank

**MODEL 07FL350-20** includes items 1-23  
3 1/2 HP with 20 gal portable non-code tank

**MODEL 07FL350-20A** includes items 1-23  
3 1/2 HP with 20 gal portable A.S.M.E. tank

**MODEL 07FL350-30A** includes items 1-23  
3 1/2 HP with 30 gal portable A.S.M.E. tank

## "FC" Series OILLESS



**MODEL 04FC200-10** includes items 1-11, 14-23  
2 HP with 10 gal portable non-code tank

**MODEL 04FC200-20A** includes items 1-11, 14-23  
2 HP with 20 gal portable A.S.M.E. tank

**MODEL 07FL350-20A** includes items 1-23  
3 1/2 HP with 20 gal portable A.S.M.E. tank

ITEM	PART NO	DESCRIPTION	QTY
18	145-0188	TUBE, bleed (teflon) "FL" series	
	or		
	145-0180	TUBE, bleed (teflon) "FC" series	1
19	145-0172	TUBE, manifold (nylon)	1
20	145-0179	TUBE, transfer	1
21	068-0017	CONNECTOR, male	1
22	012-0005	HOSE, air, 1/4" NPT (m) x 15 ft black <i>not shown</i>	
23	038-0002	AIR CHUCK, 1/4" NPT (f) <i>not shown</i>	

# PARTS DRAWING and LIST

## "F" or "FL" MANIFOLD/SWITCH ASSEMBLY includes items 1-17

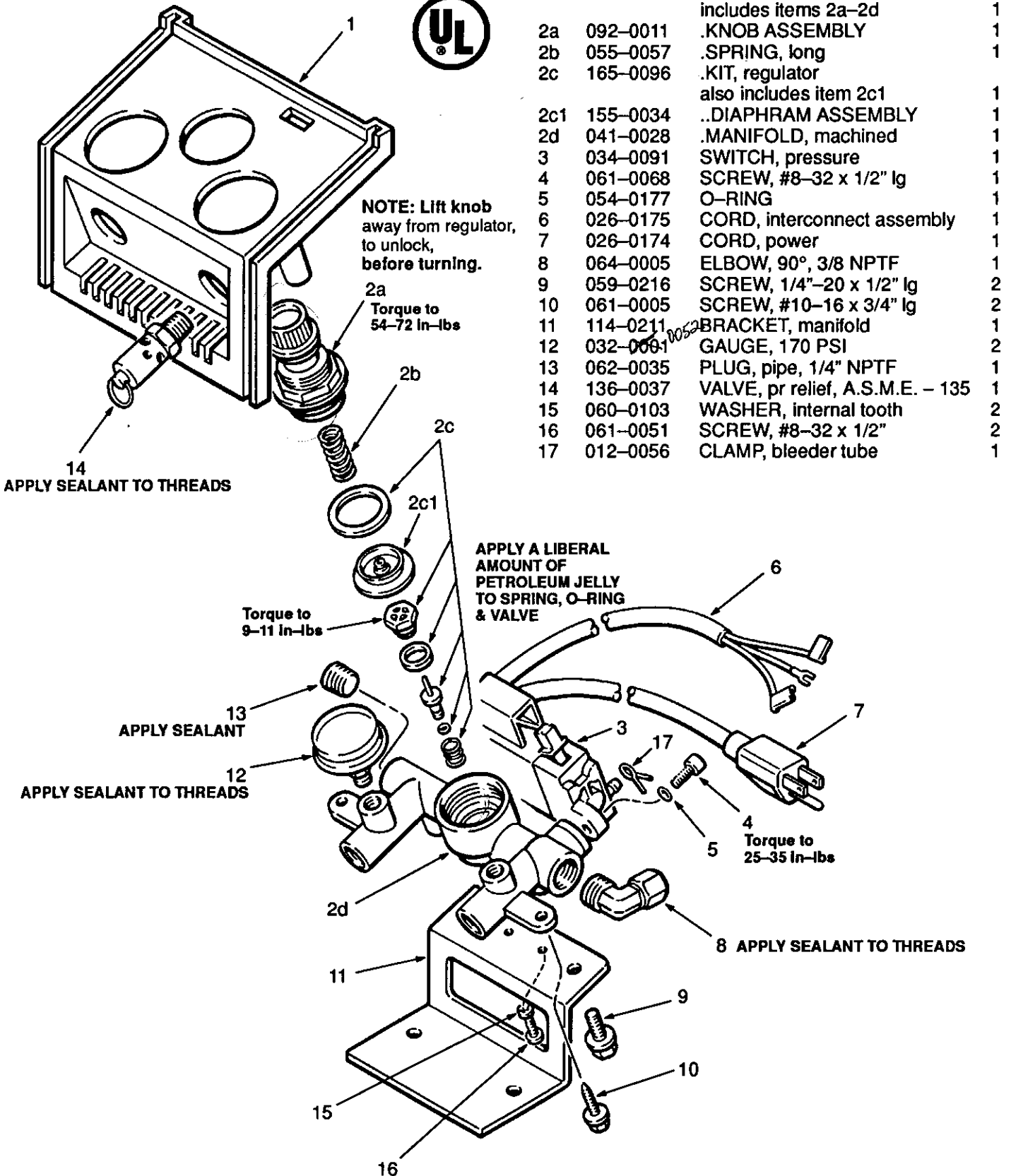

ITEM	PART NO	DESCRIPTION	QTY
1	077-0123	COVER, manifold	1
2	NA	REGULATOR/MANIFOLD ASSY includes items 2a-2d	1
2a	092-0011	.KNOB ASSEMBLY	1
2b	055-0057	.SPRING, long	1
2c	165-0096	.KIT, regulator also includes item 2c1	1
2c1	155-0034	..DIAPHRAM ASSEMBLY	1
2d	041-0028	.MANIFOLD, machined	1
3	034-0091	SWITCH, pressure	1
4	061-0068	SCREW, #8-32 x 1/2" lg	1
5	054-0177	O-RING	1
6	026-0175	CORD, interconnect assembly	1
7	026-0174	CORD, power	1
8	064-0005	ELBOW, 90°, 3/8 NPTF	1
9	059-0216	SCREW, 1/4"-20 x 1/2" lg	2
10	061-0005	SCREW, #10-16 x 3/4" lg	2
11	114-0211	BRACKET, manifold	1
12	032-0061	GAUGE, 170 PSI	2
13	062-0035	PLUG, pipe, 1/4" NPTF	1
14	136-0037	VALVE, pr relief, A.S.M.E. - 135	1
15	060-0103	WASHER, internal tooth	2
16	061-0051	SCREW, #8-32 x 1/2"	2
17	012-0056	CLAMP, bleeder tube	1

### SERVICE KITS AVAILABLE

PART NO	DESCRIPTION
141-0156	OVERHAUL KIT includes items 2, 3, 5, 10, 12 & 14

# PARTS DRAWING and LIST

## "FC" MANIFOLD/SWITCH ASSEMBLY includes items 1-16

ITEM	PART NO	DESCRIPTION	QTY
1	077-0113	COVER, manifold	1
2	NA	REGULATOR/MANIFOLD ASSY includes items 2a-2d	1
2a	092-0011	.KNOB ASSEMBLY	1
2b	055-0057	.SPRING, long	1
2c	165-0096	.KIT, regulator also includes item 2c1	1
2c1	155-0034	..DIAPHRAM ASSEMBLY	1
2d	041-0026	.MANIFOLD, machined	1
3	034-0083	SWITCH, pressure	1
4	065-0031	NIPPLE, 1/4" NPT, close	1
5	093-0001	GROMMET	1
6	026-0160	CORD, interconnect assembly	1
7	026-0176	CORD, power	1
8	064-0005	ELBOW, 90°, 3/8 NPTF	1
9	059-0216	SCREW, 1/4"-20 x 1/2" lg	2
10	061-0005	SCREW, #10-16 x 3/4" lg	2
11	114-0211	BRACKET, manifold	1
12	032-0052	GAUGE, 200 PSI	2
13	062-0035	PLUG, pipe, 1/4" NPTF	1
14	136-0037	VALVE, pr. relief A.S.M.E. - 135	1
15	093-0005	PLUG, button	1
16	080-0047	TUBE, shrink 4.25" lg	1

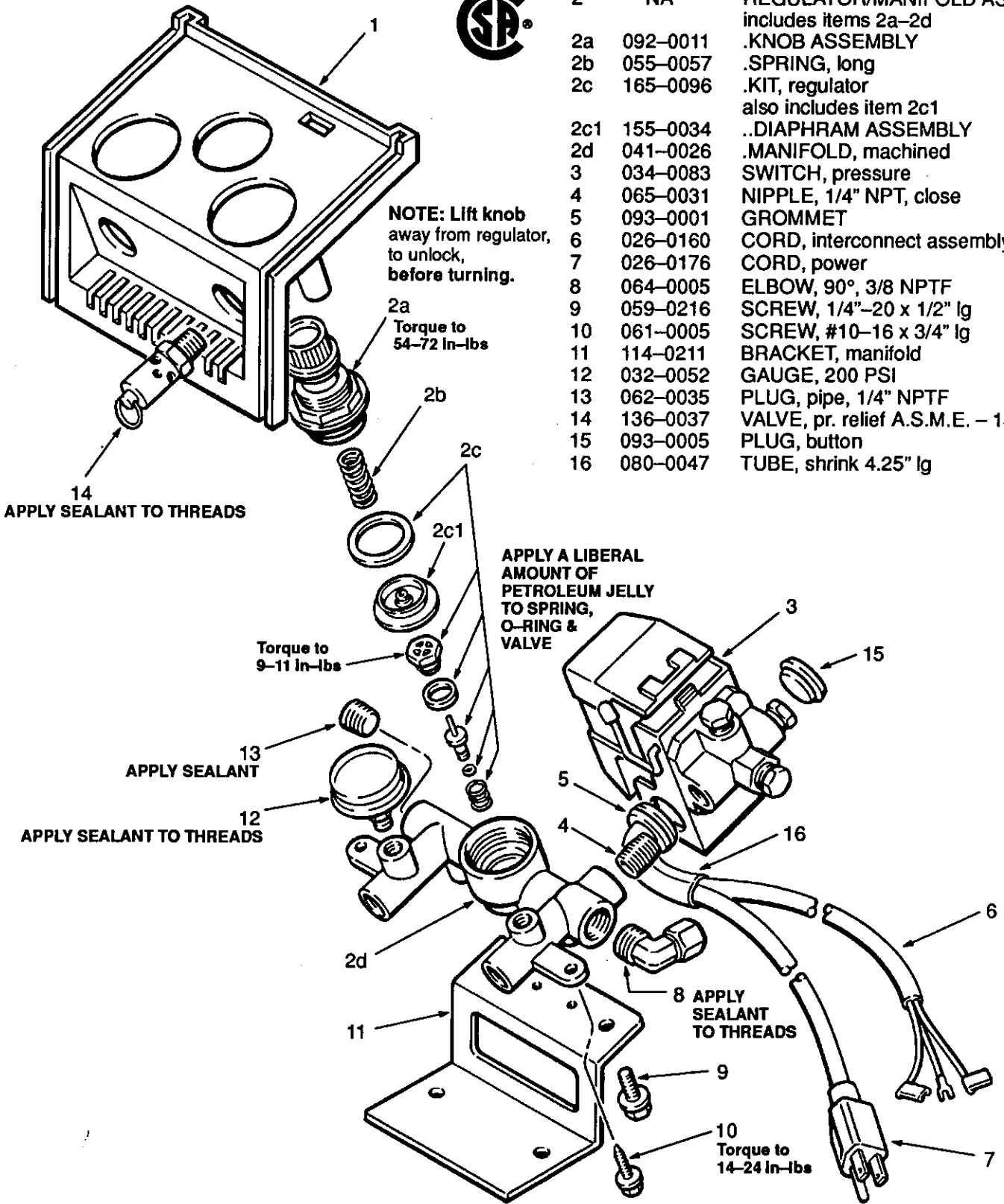

### SERVICE KITS AVAILABLE

PART NO	DESCRIPTION
141-0156	OVERHAUL KIT includes items 2, 3, 5, 10, 12 & 14

# PARTS DRAWING and LIST

## PUMP SPECIFICATIONS

WEIGHT - 34 LBS  
MAX RPM - 3500

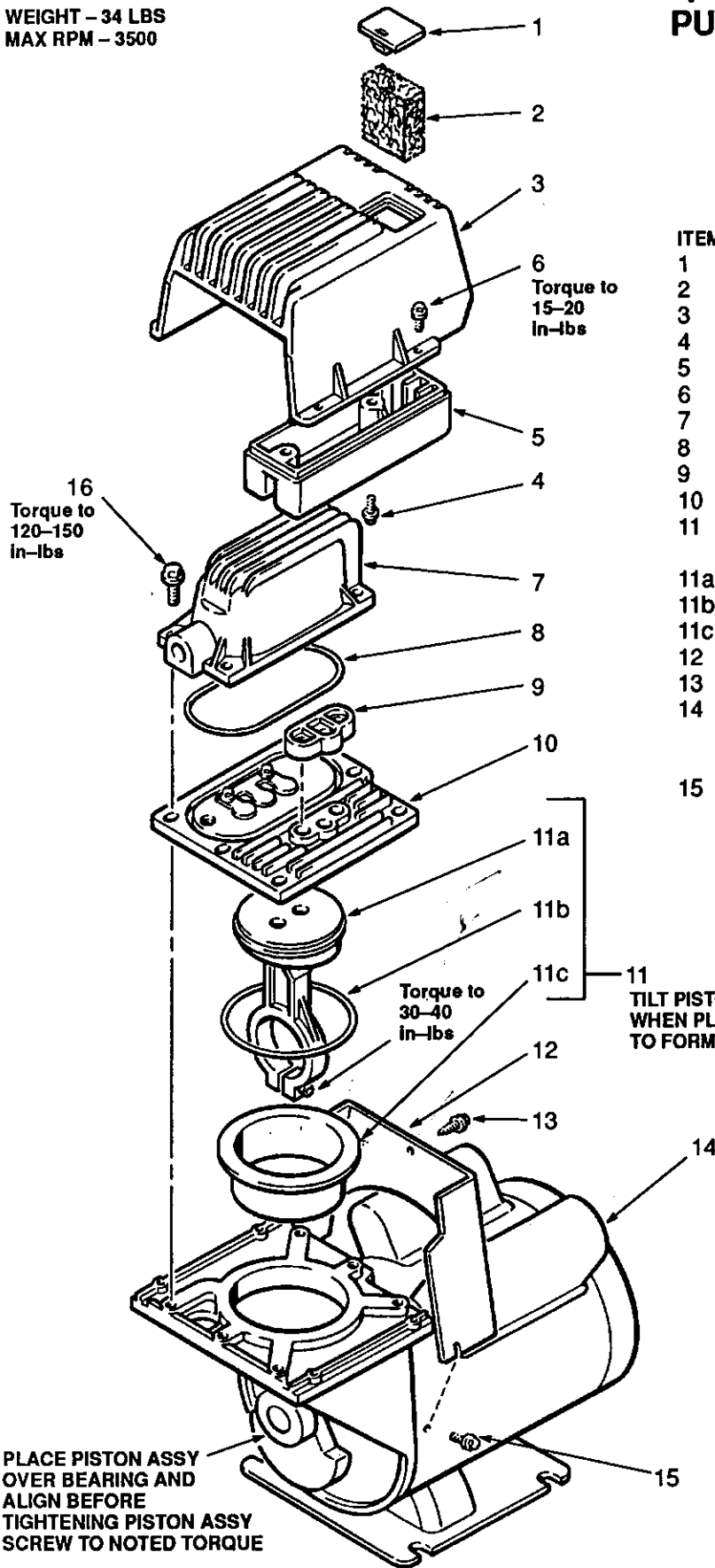

## "F", "FL" & "FC" Series OILLESS PUMP/MOTOR ASSEMBLY

**2 H.P. 040-0172** includes items 1-15

**3 HP** includes items 1-13, 15. *Motor item 14 is not available for service, replace with complete*

Pump/Motor Assembly for 3 1/2 HP

**3 1/2 HP 040-0174** includes items 1-15

ITEM	PART NO	DESCRIPTION	QTY
1	077-0118	COVER, filter	1
2	019-0152	FILTER, element	1
3	077-0117	COVER, pump	1
4	061-0060	SCREW, #8 -32 x 3/4" lg	4
5	019-0151	MANIFOLD, intake	1
6	061-0061	SCREW, #8 -32 x 3/8" lg	4
7	117-0009	MANIFOLD, exhaust	1
8	054-0157	O-RING, exhaust	1
9	046-0231	SEAL, intake	1
10	043-0151	VALVE PLATE ASSEMBLY	1
11	048-0074	PISTON & CYLINDER ASSEMBLY includes items 11a-11c	1
11a	NA	.PISTON ASSEMBLY	
11b	054-0158	.O-RING, cylinder	1
11c	NA	.CYLINDER, hardened	1
12	142-0077	DUCT, cooling	1
13	061-0055	SCREW, #10 tapping x 1/2" lg	1
14	NA	MOTOR ASSEMBLY must be purchased as complete Pump/Motor assembly	1
15	061-0062	SCREW, 1/4" - 20 x 1" lg	6

### SERVICE KITS AVAILABLE

PART NO	DESCRIPTION
046-0234	SEAL KIT includes items 8, 9 & 11b

**11**  
TILT PISTON ASSY (11a) SLIGHTLY  
WHEN PLACING INTO CYLINDER (11c)  
TO FORM LIPS ON SEAL

PLACE PISTON ASSY  
OVER BEARING AND  
ALIGN BEFORE  
TIGHTENING PISTON ASSY  
SCREW TO NOTED TORQUE